



INSTRUCTIONAL BOOKLET

INSTALLER: GIVE THESE INSTRUCTIONS TO THE OWNER AFTER
INSTALLATION FOR THEIR FUTURE REFERENCE



LIMITED WARRANTY – June 01, 2009

REMCO DRIVE SHAFT COUPLING (“REMCO”), a product by SUPERFLOW TECHNOLOGIES GROUP warrants their products to the original purchaser for a period of one (1) year from the original date of purchase.

REMCO WARRANTS THEIR PRODUCTS AGAINST DEFECTIVE MATERIALS AND WORKMANSHIP. THIS WARRANTY IS VOID IF THE PRODUCT IS DAMAGED BY ACCIDENT OR UNREASONABLE USE, NEGLIGENCE, IMPROPER SERVICE OR OTHER CAUSES NOT ARISING OUT OF DEFECTS IN MATERIAL OR WORKMANSHIP. THIS WARRANTY IS NOT SUBJECT TO MISUSE, ABUSE, ASSIGN OR TRANSFER.

REMCO will either repair or replace during the above one (1) year all defective parts. Defective parts must be delivered or shipped prepaid and insured to **REMCO**. Parts must be accompanied with proof of date and place of purchase. The exclusive remedy under any and all warranties and guarantees expressed or implied is limited to the repair and/or replacement as provided herein. In no event shall **REMCO** be liable for any indirect, incidental, special, exemplary, punitive or consequential damages of any nature whatsoever, including, without limitation, any such damages for loss of profits, loss or delay of equipment use or other intangible damages.

REMCO reserves the right to make changes and/or improvements in the product at any time without notice. **REMCO** shall not be obligated to incorporate such changes and/or improvements in products previously sold, nor are obligated to replace previously sold products with products incorporating such changes and improvements.

No person, agent, distributor, dealer or company is authorized to change, modify or extend the terms of these warranties in any manner whatsoever. Notwithstanding any maximum limitation periods set forth under any applicable law or statute, the time within which an action must be commenced to enforce any obligation of **REMCO** arising under this warranty or under any applicable statute or law is hereby limited to the duration of the warranty set forth above, commencing from the date of purchase.

ALL WARRANTIES IMPLIED BY STATE LAW, INCLUDING THE IMPLIED WARRANTIES OF MECHANICABILITY AND FITNESS FOR A PARTICULAR PURPOSE, ARE EXPRESSLY LIMITED TO THE DURATION OF THE LIMITED WARRANTIES SET FORTH ABOVE. WITH THE EXCEPTION OF ANY WARRANTIES IMPLIED BY STATE LAW AS HEREBY LIMITED, THE FOREGOING WARRANTY IS EXCLUSIVE AND IN LIEU OF ALL OTHER WARRANTIES, GUARANTEES, AGREEMENTS AND SIMILAR OBLIGATIONS OF MANUFACTURER OR SELLER WITH RESPECT TO THE REPAIR OR REPLACEMENT OF ANY PRODUCTS OR PARTS.

This warranty gives you specific legal rights and you may also have other rights which may vary from state to state. Some states do not allow limitation on how long an implied warranty lasts, when an action may be brought, or the exclusion or limitation of implied warranties or incidental or consequential damages, so the above provisions may not apply to you.

The foregoing warranty and the sale of the **REMCO** products to you shall be governed by and construed in accordance with the laws of the State of Nebraska (U.S.A.), without regard to principles of conflicts of laws, and you irrevocably consent to and submit to the exclusive jurisdiction and venue of the state and federal courts in Omaha, Nebraska, for the purpose of all legal proceedings arising out of or relating to the foregoing warranty and the sale of the **REMCO** products to you.

REV: 6.12.09

Part I: General Information

IMPORTANT:

REMCO does not balance SKU-1 and SKU-2 (DSC) Drive Shaft Couplings and do not guarantee them to be vibration free. We do not assume any responsibility or expenses that may occur.

The Drive Shaft Coupling has been created for convenient towing of rear wheel drive vehicles equipped with automatic transmissions. There are a few manual transmission rear wheel drive vehicles that will require the drive shaft coupling. The drive shaft coupling will disconnect the drive shaft by remote control from the driver's seat. This eliminates the old procedure of unbolting the drive shaft whenever the car is to be towed.

1. The Coupling Assembly

The coupling assembly provides the disconnecting member between the rear axle and the transmission. It becomes an integral part of the drive shaft. The coupling contains a shifting collar which, when moved one way, disengages the coupling so that the vehicle may be towed. In the other direction, the collar engages the coupling so the vehicle may be driven.

2. The Shifter Linkage Assembly

The shifter linkage assembly is mounted on the differential. It has two shift blocks that fit into the collar on the drive shaft coupling. The shift blocks slide the collar on the coupling to engage or disengage the drive shaft.

3. The Remote Control Cable Assembly

The cable extends the control of the shifter linkage from the rear axle to the driver's seat. The mounting position for the control knob is, either on the driver's side of the transmission tunnel or in a van where the floor is flat; the cable would run left of the engine cover. In either case, the cable always runs down the middle of the vehicle.

Part II: Tools Required

Common auto mechanic hand tools

Hand wrenches: 1/4", 7/16", and 1/2" Flat blade screwdriver

Diagonal side cutters

Hammer

Large driving punch, to make a 7/16" hole in floorboard

3/16" punch

Vise for installing u-joints

Hoist, jack, jack stands, & wheel blocks. (Hoist is the easy way! but not everybody has one.)

Part III: Parts List

1-REMCO Drive Shaft

Most orders are sold with a customer-made drive shaft with the **REMCO** coupling welded into the drive shaft. On some vehicles **REMCO** can supply only the coupling. This will come without the drive shaft. The coupling has 3 pieces: The splined stub welded into the drive shaft, the round splined collar and the splined yoke.

1-Shifter linkage assembly

This unit is a black piece of steel channel, with linkage that is plated with yellow zinc chromate and bolted to the channel. Each Shifter assembly is unique for each vehicle.

1-Hardware Bag

Enclosed in the bag are these parts:

1- Cable control bracket 1- 1/4" x 3/4" bolt

1- 1/4" lock washer

1- 1/4" nut

2- 1 1/2" sheet metal screws

1- Wescon fitting with 3 parts: 1 - barrel nut, 1 - #8-32 screw and 1 - concave washer

1- Cable clamp

2- Cable clamps with coating

2- 3/4" self-tapping screws

1- Shift Cable

The cable has a black outer housing with a stainless steel inner cable wire running thru the outer housing. The cable knob is attached to the inner cable.

1- Instructions enclosed in an envelope

The instruction book, visor sheet and product information.

Before you disassemble the car make sure you have the above parts. Inspect and familiarize yourself with the parts. Check the parts list along with the packing slip. Some

vehicles require extra parts (u-joints, flanges and slip yokes are just an example of parts that might be needed) depending on the vehicle. This may be the situation on your vehicle.

PART IV: Raise the vehicle and inspect the drive shaft

- a. If you are lucky enough to have a hoist, raise the vehicle. Make sure the rear axle is supported. **It cannot hang down.**
- b. If not place the car on a hard level surface and block the front wheels.
- c. Place the transmission in Neutral and release the parking brake.
- d. Jack the rear of the car up and place jack stands under the axle (not frame) to hold the car high enough for comfortable work in the area of the rear u-joint. Lower the jack to allow the jack stands to carry the vehicle's full weight.

SAFETY FIRST - Do not get under any vehicle that is supported only by a jack. Be sure vehicle is properly blocked and supported by jack stands before getting under it.

- e. If the drive shaft coupling is supplied without a replacement drive shaft turn to page 25 and follow the directions for reworking the factory drive shaft. If you are replacing the factory drive shaft with the REMCO drive shaft continue to step "f".
- f. **IMPORTANT: Before removing the factory drive shaft, compare the factory shaft with the REMCO shaft. Check to make sure the length of each shaft is roughly the same (see illustration 2 below) the length should be no more than a 1/4" difference between the two drive shafts. If the REMCO drive shaft is different, you must stop immediately and call REMCO to correct the problem.**

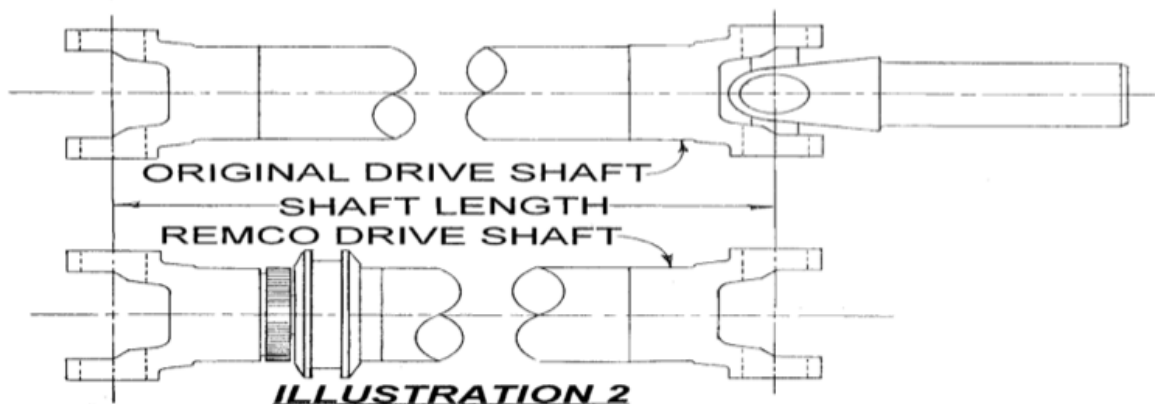

- g. If the factory drive shaft has flanges or a male-female slip spline, you want to **mark the exact position** of the flanges or slip spline. Using a marker, chalk, or scratch awl will help you to install the REMCO drive shaft in the same position as the factory drive shaft.

Part V: Remove factory drive shaft and prepare the REMCO drive shaft for install

- a. If you need help with u-joint removal and installation refer to Part VI, page 8. If not, continue with step “b” below.
- b. Remove the factory drive shaft from the vehicle. If the drive shaft has a carrier bearing, remove the rear shaft only. Some drive shafts have a male-female slip built into the drive shaft. REMCO makes a drive shaft with the male spline, which will slip back into the factory female slip. **Before you pull the factory shaft apart, be sure to mark the position of the male-female spline so you can install the REMCO spline back in the same position.** The blue material on the male slip is there to make a tight fit when slipped into the female slip. **Don't try to remove the blue material!**
- c. If you have a drive shaft with the blue male spline, then install the rear u-joint and any flange that is necessary, depending on the vehicle.
- d. The slip yoke on the shaft needs to be removed from the factory drive shaft and installed on the **REMCO** drive shaft.
- e. Care needs to be taken to prepare the u-joints for installation into the yokes. It is necessary to completely lubricate each u-joint prior to installation to avoid premature failure. U-joints have just enough grease to hold the needle bearings in place for shipment purposes. **The following instructions are very important.**

Remove the four bearing caps from the u-joint cross. Install the grease zerk into the cross. Using a grease gun on the zerk, pack enough grease into the cross until the grease comes out each of the cross ends. **The four bearing caps need to be filled with a finger full of grease.** The u-joint is ready to be installed onto the **REMCO** drive shaft (**see Illustration 1**).

- f. **Please read carefully. This part is very important and will affect the entire installation.** Check the u-joint movement in the yokes. A bind or catch can result from the bearings not being seated against the snap rings. Tap the ears of the yoke sharply to relieve any bind. This tapping will jar the cap against the snap ring, allowing the cross to swivel smoothly. Do not install the drive shaft unless the u- joints move easily with no binds. Check to see that all snap rings are properly seated in their grooves.

NOTE: On most GM vehicles an inside snap-ring **must** be installed on the 2 rear caps that are strapped to the differential /pinion yoke.

- g. If you have the **REMCO** drive shaft ready, set it off to the side and refer to Part VII.



ILLUSTRATION 1

Part VI: U-joint removal and installation

The vehicle manufacturers install different series u-joint yokes, depending on the size of the vehicle. REMCO adapts to the foreign built cars by using an 1100 or 1310 series yoke. REMCO adapts to the American built cars by using a 1310, 1350 or 1410 series yoke **(See Illustration 2, below)**.

- b. Some u-joints are a standard series cross and bearing and some u-joints are a combination series cross and bearing. The standard u-joint means the cross is the same length both directions and the four bearing caps are the same diameter. The combination series u-joint means the cross could be a different length one direction than the other and two of the bearing caps could be a different diameter.
- c. Some vehicles require a combination u-joint because the yokes on the **REMCO** shaft are one series and the yokes on the drive shaft are another series

ILLUSTRATION 2



OUTSIDE SNAP RINGS



INSIDE SNAP RINGS

- d. There are three styles of u-joints that REMCO must adapt to. One is a u-joint with snap rings. They either have inside snap rings or outside snap rings holding the caps in the yoke. The second is on GM vehicles, which use a plastic injection to retain the bearing cap in the yoke. The third style is on some foreign vehicles. It is a u-joint that is installed in the yoke and then swedged around the bearing caps to hold them in place (**see Illustration 2, page 8**).
- e. The snap ring style u-joints are fairly easy to remove and install and the following directions will help you with the installation. The plastic injection u-joints are a little tougher. They can be removed by using sufficient press force to shear the plastic, or by softening the plastic by heating it to 300 to 350 degrees F. and then driving out the bearings. The third style u-joint on some foreign vehicles is a non-replaceable u-joint. REMCO sends a flange and u-joint to mate the REMCO shaft to the foreign vehicle.
- f. Place the u-joint in a vise as shown in (**see Illustration 3, page 11**). The vise jaw should be covered with soft metal to prevent damage to the u-joint bearings.
- g. Select a socket or short metal tube slightly larger than the diameter of the bearing cap. With a hammer, drive the slip yoke down so the top cap will enter through the top of the yoke. Turn the u-joint over, clamp the exposed bearing in the vise and tap the yoke from

the underside. Care should be taken not to crush the bearing cap.

- h. Remove the second bearing cap in a similar manner as the first. The cross may now be removed from the yoke.
- i. Install the u-joints with slip yoke and any flanges that are necessary onto the REMCO drive shaft.
- j. Care needs to be taken to prepare the u-joints for installation into the yokes. It is necessary to completely lubricate each u-joint prior to installation to avoid premature failure. U-joints have just enough grease to hold the needle bearings in place for shipment purposes. **The following instructions are very important.**

Remove the four bearing caps from the u-joint cross. Install the grease zerk into the cross. With a grease gun on the zerk, pack enough grease into the cross until the grease comes out each of the cross ends. **The four bearing caps need to be filled with a finger full of grease. (See Illustration 1, page 7).** Now the u-joint is ready to be installed onto the REMCO drive shaft.

- k. Position the cross into the yoke and shift it to one side so that one of the bearing caps may be pressed into the end of the yoke. Avoid jarring the bearings while making the assembly, which could knock the rollers out of position.
- l. With the use of the vise (or press), press the one bearing into position so that the snap ring may be installed. **Caution:** Keep bearings square with the yoke when pressing so they do not bind. When assembling bearings with outside snap rings a push tool will be needed. A socket slightly smaller on its outside diameter than the bearing makes a suitable tool. Do not press on the center area of the bearing.
- m. Side shift the cross part way out of the pressed in bearing to start the second bearing on the cross. This will hold rollers of both bearings in position.
- n. Press in the second bearing into position allowing the first bearing to seat against its snap ring. When assembling bearings with inside snap rings it may be necessary to use a bushing to support the yoke, allowing clearance for the first bearing to move against its snap ring. A large socket makes a suitable tool. If the bearings (or seals) do not come together with the cross, disassemble and inspect for a roller out of position.
- o. Install the second snap ring.
- p. **Please read carefully. This part is very important and will affect the entire installation.** Check the u-joint movement in the yoke. A bind or catch can result from the bearings not being seated against the snap rings. Tap the ears of the yoke sharply to relieve any bind. This tapping will seat the cap against the snap ring, allowing the cross to swivel smoothly. Do not install the drive shaft unless the u- joints move easily with no binds. Check to see that all snap rings are properly seated in their grooves.
- q. Return to Part V, section “b”

ILLUSTRATION 3

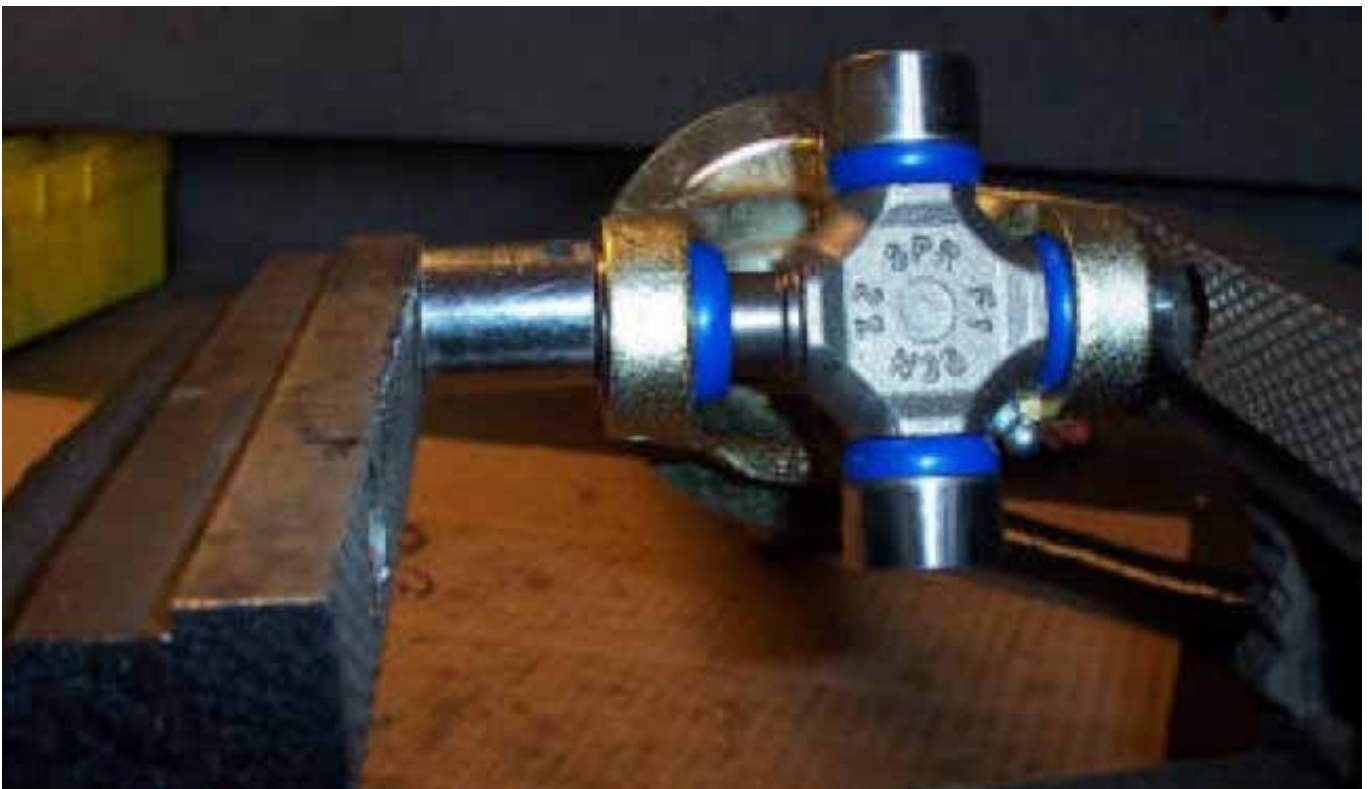



Part VII: Routing the shift cable

Once the factory shaft is removed and you have the REMCO drive shaft ready for installation, now install the shift cable. The cable will be installed before the REMCO drive shaft is installed. It is very important to follow the cable installation step by step.

a. **Plan the routing of the cable.**

The cable knob is mounted by the driver's seat, close to the middle of the vehicle. Most vehicles have a transmission tunnel where the knob would be mounted. The cable knob will be mounted to a bracket that is screwed to the transmission tunnel or to the floor of the vehicle (depending on the type of vehicle). The cable goes through the floorboard of the vehicle and runs down the drive shaft tunnel to the differential third member. A van would require the knob to be mounted between the two seats and left of the engine cover, but it will still run down the middle of the vehicle. If the cable has a slight curve, as it goes thru the floor or a slight curve down to the differential will be fine, but basically it will run straight down the middle of the vehicle. Do not stray from this planned route- any bends will cause the cable to bind.

b. **Installing the shift cable.**

Now that you know where the cable is to be routed, punch the hole in the floorboard. Take the large driving punch and punch the hole 8" to 12" back from where the cable bracket will be mounted. Please remember that the cable will run down the drive shaft tunnel so punch the hole on the side of the tunnel in front of the driver's seat with the 7/16" punch. With the punch still in the hole push forward and down on the punch. With a long punch you can use leverage to bend the sheet metal so when the cable goes thru the hole it will angle towards the rear of the vehicle giving the cable a slight curve as it goes thru the hole. If you don't push down on the punch the hole will make the cable go straight towards the ground and then it will have a sharp bend at the floorboard as it

goes back to the rear.

NOTE: Using a punch makes the job quick and easy. Don't use an electric drill. Using an electric drill will cause the carpet to rap around the drill bit. It also makes it harder to see the holes.



The shift cable has a nut and lock washer screwed to the knob. Take them off to install the mounting bracket that is in the hardware bag. Take the mounting bracket and observe the bend in the bracket. It's at an angle so the cable knob angles up. Slide the bracket on the cable, so that the knob will be angled upward when mounted on floor. Install the lock washer and nut back on the shift handle, and tighten the nut against the bracket. Place the cable thru the hole in the floor and locate the bracket 8" to 12" forward of the hole. With a 3/16" punch, hold the cable bracket in place and punch one hole and screw in one of the 1/4" screws. Punch the other hole and install the second screw. Go under the vehicle and mount the cable to the floor-board. This will depend on whether the floor has a drive shaft tunnel or the floor is flat. If it has a tunnel, mount the cable to the floor in the tunnel. If it is flat (example a pickup or van), then run the cable down the middle of vehicle (**see Illustration 4**).

Supplied in the hardware bag are three cable clamps. Two of the cable clamps are black-coated. Take the two self tapping screws and the two black-coated clamps supplied in the hardware bag and clamp the shift cable to the bottom side of the floor board or cross members, depending on the vehicle. The black-coated clamps will make the cable rigid as it goes back towards the shifter. The last black-coated clamp should be roughly 18" to 24" from the shifter, but no closer. Take the shifter linkage assembly and remove the u-bolt. Hold the assembly against the differential and this way you can get a good idea of where the cable will run from the last black-coated clamp to the cable support arm on the shifter linkage assembly. When you install the last black-coated clamp, have the cable lying in a straight line to where the cable will clamp to the cable support arm, using the third clamp, (this will be the non coated clamp).

NOTE: Now that the cable has been routed through the floor board and secured with the black- coated clamps, using a silicone sealant, seal the hole in the floor board that you routed the cable through. This will keep out dirt and moisture and protect the interior of your vehicle.

Looking at the cable installation, the front of the cable should now be installed with a slight curve going through the floorboard and rigid as it goes back to the last black-coated clamp, which is roughly 18"-24" away from the shifter. From the last black-coated clamp it will angle down, but straight to where the shifter linkage will be mounted on the differential. The last 18"-24" will move up and down as the differential moves over bumps and dips in the road.

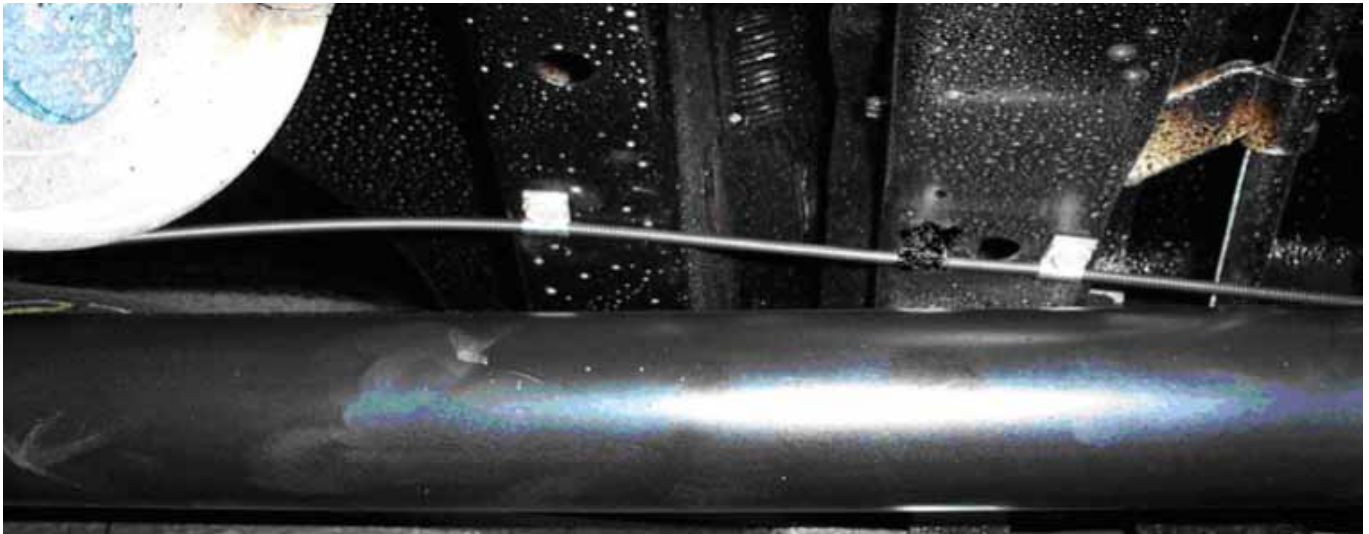

Part VIII: Install REMCO drive shaft

- a. Clean the flange surfaces on the car and on the drive shaft. Clean and re-oil slip yoke with motor oil if it has become dirty.
- b. If you have a drive shaft with a male-female slip, you now want to install the REMCO drive shaft in the same position that you removed the factory drive shaft. **This way the u-joint will be in the same phase as the factory shaft was.** If you don't keep the rear joint in phase with the front u-joint, vibrations and other problems occur. Remember that the blue spline on the REMCO drive shaft is there to make a tight fit when slipped into the female slip. **Don't try to remove the blue material!**
- c. Install the REMCO drive shaft assembly. If the drive shaft has flanges, bolt the companion flanges in the same position as the original drive shaft that you marked (**refer to Part IV, step "g", page 5**) when removing the factory drive shaft. Properly tighten all bolts.
- d. If you are installing a drive shaft on the 1997 and newer Ford F-150 pickups. REMCO has made a two-piece drive shaft and eliminated the one-piece factory shaft. Follow the instructions that come with that particular drive shaft.
- e. In Part IX you need to test-drive the vehicle. Secure the shift cable underneath the vehicle so it won't be damaged by hanging loose.

Part IX: Test drive the vehicle

- a. With the REMCO drive shaft installed, you now want to test drive the vehicle. This is before you install the shifter mechanism. The reason for this test is to make sure the drive shaft is operating properly and that there are no vibrations. These vibrations can start at 5 mph on up to highway speeds.
- b. Drive the vehicle on a highway or interstate. This way you can test the full range of speeds. Normally, if you have a vibration at speeds under 40, it has to do with a u- joint. A vibration at the higher speeds will normally be in the drive shaft balancing itself.
- c. Be sure to drive the vehicle in the full range of speeds. From city driving speeds up to highway speeds. You need to know that the drive shaft is just like it was when you started this project. You should not have a vibration. If everything is fine then continue to Part X, if not go to step “d”.
- d. If you have a high-speed vibration (over 40), stop. **Do not install the shifter. Call REMCO.**
- e. If it is less than 40 mph, it may be a problem with au-joint, snap ring or the phasing of the drive shaft. Look at the snap rings to see if they are in place. Sometimes they will snap out and this allows the u-joint to move in the yoke. On most GM vehicles the 2 rear inside snap rings may have been left off.
- f. If the snap rings are all in place then we need to remove the drive shaft from the vehicle and check to see if the joints are operating smoothly or do they have binds or catches in them.
- g. If you have a drive shaft that has a male-female slip spline, you need to make sure the rear drive shaft is in phase with the front drive shaft. The u-joints at each end must be in a straight line with each other. If the slip spline is one or two teeth off, this could cause a vibration.
- h. If the above solutions do not solve the problem, stop. **Call REMCO.**

Part X: Installation of the Shifter linkage assembly

VERY IMPORTANT: PROPER ALIGNMENT OF THE SHIFTER LINKAGE ASSEMBLY CAN ONLY BE MADE IF THE REAR AXLE IS SUPPORTED. DO NOT LET THE REAR WHEELS HANG DOWN. THEY MUST BE SUPPORTED. DO NOT USE A FRAME HOIST OR BUMPER HOIST. NOTE: MAKE SURE THAT THE JACK STANDS OR LIFT IS UNDER THE REAR AXLE SO THAT THE REAR AXLE WILL BE IN THE SAME POSITION AS WHEN IT IS SITTING ON THE GROUND.

- a. The shifter assembly is designed for mounting to the vehicle’s differential housing, also called the rear end, third member or hogs head. **Please do not try to install the shifter at the transmission or carrier bearing.**
- b. Each shifter linkage assembly is made for a specific differential. The shifters are

basically the same in design. Some will have jack bolts, saddles and u-bolts, but some will not. The steps listed here in **Part X** are general instructions to install the shifter assembly. In the center of the book is the “**supplemental illustration**” pertaining to the specific shifter assembly for the vehicle you are working on.

- c. Engage the coupling on the drive shaft by moving the shifting collar into its rearward position. This is the locked position for driving the vehicle.
- d. Remove the u-bolt and hold the shifter linkage assembly into position under the coupling and differential. The white shift blocks slide up half way into the shifting collar. The main frame of the assembly is designed to sit against the bottom of the differential. Never on the top or sides the differential.
- e. While holding the assembly upward against the differential and rearward against the collar, make an identifying mark on the differential through the u-bolt holes on the main frame. Take the u-bolt or a scratch awl from the bottom side of the main frame and make the marks on the differential. Remember in step “b”, that these are general instructions. You may only need to make one mark for the u-bolt, or no marks depending on the vehicle. The supplemental illustration will show the specific information. The top right and bottom left pictures in the supplement will show you exactly how the u-bolt will fit.
- f. The u-bolt will be positioned from the topside down. According to the top right picture you will drill or notch the webbing. The notch or drilled hole keeps the u-bolt from sliding. Do not notch or drill so much of the webbing that it won't hold the u-bolt in a stationary position. The u-bolt is 5/16" in diameter. Using a 3/8" drill bit, drill the hole or holes. If it says to notch the webbing, make the notch for the 5/16" u-bolt, no bigger. The u-bolt will be positioned from the topside down. Lower the u-bolt down around the differential. It should fit properly around the differential. You may need to bend it slightly to fit thru the holes or notches. **Do not attempt to bend the u-bolt over the existing webs.**
- g. With the u-bolt in place, remove the tie wire from the shifter linkage assembly. Mount the assembly to the differential. The shift fork with the white blocks will guide the linkage into position as the u-bolt is tightened. Make sure the shift collar is in the engaged position and keep rearward pressure on the linkage as you tighten the plate to the differential. If the assembly has front saddles, make sure they sit against the differential. If it has rear saddles you may have to add or remove washers under the saddle. Check to see that the assembly is level side to side. If the shifter is equipped with jack bolts; tighten the jack bolts against the differential. This will prevent side movement of the main frame. The shifter assembly that you are installing may or may not have these certain steps. Again the supplemental illustration pertains to the vehicle you are working on. Pay close attention to that section.
- h. Inspect the clearances which will be needed around the linkage as the rear axle moves up and down under the car. Interferences could occur between the exhaust system, brake lines, floor pan tunnel and the gas tank.

Part XI: Adjusting the shifter linkage assembly

- a. There are 4 bolts holding the pivot brackets. (See bolts “A” in illustration 6, page 19) There is a pivot bracket on each side of the frame. These pivot brackets hold the shifting fork. Slots under these brackets provide for an adjustment of the white shifting blocks to the shifting collar. Loosening these bolts will allow the pivot brackets to move up, down, or forward and backwards. You can make the adjustments independently. By inspecting the arms that have the white blocks attached, you may only need to adjust one of the pivot brackets.
- b. The following adjustments must be made at the same time.
 - 1) Adjust each pivot bracket arm so the two shifting blocks are resting against the rear face of the shifting collar groove.
 - 2) Raising or lowering both pivot bracket arms will adjust the height on the shifting blocks. The shift blocks need to be half way up in the shifting collar. The shifting fork can be moved up or down to get them centered half way up in the shifting collar. With the white blocks centered in the collar, you can take your index finger and slide it between the collar and the shift fork.
- c. The above adjustments are accomplished together. Once complete, lock the assembly by tightening the four bolts “A”. This will give you a “rough” adjustment.
- d. Now you are ready to “fine tune” the unit. By moving the control lever backward and forward, shift the coupling slowly in and out of engagement. The collar should move smoothly and evenly without a feeling of binding. If a bind occurs, it is generally caused by one side of the fork pushing the collar before the other side of the fork touches the collar. The white shift blocks on the forks need to touch the collar at the same time. A close visual inspection of the blocks will reveal if one block touches the collar before the other block touches. For the side that needs adjusting, loosen the pivot bracket with the “A” bolts just enough so that you can tap the pivot bracket without too much movement. NOTE: It is very important that this adjustment be made as accurately as possible.
- e. The forks with the white shift blocks are sometimes bent inward as to pinch the collar. Bend the arms out to give clearance between the blocks and collar. The only time the blocks touch the collar is when the collar is being shifted in or out of engagement. Any other time the blocks should not touch the collar. The blocks should float in the collar.
- f. The shift fork is held into the pivot brackets. This fork should have about 1/16” of side-to-side movement. This allows the shift fork arms to move when the drive shaft is spinning. This movement helps the shift blocks to move and extends the life of the blocks.
- g. With the shifter assembly adjusted correctly, you will be able to shift the collar in and out of gear by hand with the control lever. If the collar does not shift smooth and with ease you need to look closely at the shift blocks and make sure they are adjusted per the above steps.

h. If it does not shift smoothly and you have gone thru the above steps, stop. Call REMCO.

ILLUSTRATION 6

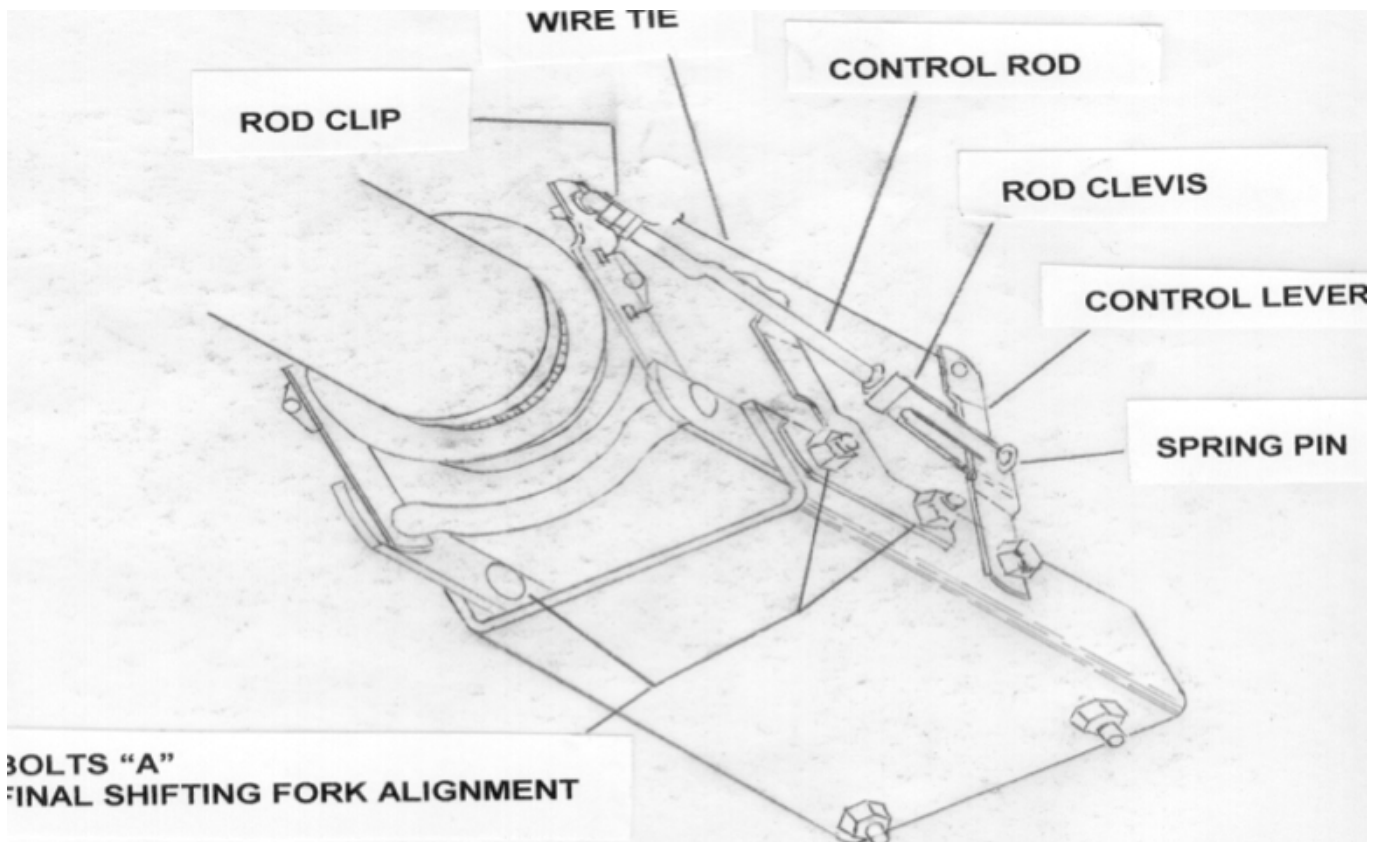

Part XII: Attaching cable to the shifter assembly

Now you finally can work on the cable that has been hanging in your way.

NOTE: BE SURE THE ENGAGING COLLAR IS ALL THE WAY TO THE REAR IN THE ENGAGED POSITION.

- a. At the driver's seat is the control knob. Pull the knob forward 2 feet from the mounting bracket. This way the inner control wire will not be cut when you shorten the outer cable housing at the shifter linkage.
- b. The shift cable should run in a straight line from the last #3 clamp on the floorboard to the cable support bracket (better known as the T-bracket), on the shifter assembly. See illustration 6.
- c. Remove the vinyl dust cap from the end of the outer cable housing. Keep the dust cap to re-install in step "g". Hold the cable housing into position on the T-bracket. Make sure you have a bow or arch in the cable housing, between the last #3 clamp and the T-bracket. This will allow the cable to flex up and down when the differential is moving. With the use of diagonal side cutting pliers, cut the outer cable housing about 3 inches past the T-bracket. **(WARNING - do not cut the outer cable housing unless the inner control wire has been pulled forward.)**
- d. Take the last clamp, (does not have the #3 stamped on it) and place it around the outer cable by the T-bracket. With the bow in the cable, line up the clamp with the mounting hole of the T-bracket. This will be the final position for the clamp. Take the side cutters and crimp the clamp. **(See Illustration 7, page 21)**. This crimp will give the clamp a better grip into the outer cable housing.
- e. Take the 1/4" bolt, lock washer, and nut, and with the bow in the cable, bolt the clamp and cable to the T-bracket.
- f. Cut off the excessive cable housing so that about one-half inch of the cable housing extends beyond the clamp.
- g. Push the control knob in flush to the mounting bracket on the floorboard. Slide the vinyl seal over the inner cable wire and install it onto the outer cable housing.
- h. Install the wescon fitting, which has three parts, the barrel nut, #8-32 screw and the concave washer **(see illustration 7, page 21)**. Thread the screw into the hexagon side of the barrel nut. Install the barrel nut into the control lever. It slides into the lever so that the screw head will point towards the tire. Slide the concave washer on the barrel nut so the concave or "bowl" part of the washer is facing the control lever. Take the cable wire and slide the wire thru the small hole in the barrel nut. The concave washer is now between the cable wire and the control lever.
- i. Pull the control knob forward to have a 1/2" space between the control knob and the bracket on the floor. This 1/2" space at the control knob this will allow the cable to flex when the differential moves up and down over dips, speed bumps or potholes as the vehicle is being driven.

- j. Tighten the screw into the barrel nut. Be sure the coupling is engaged for driving before the screw is tightened. With the screw tight, cut the excess wire roughly a 1/2" back from the barrel nut.
- k. Look closely at the alignment of the cable. It should angle smoothly from the last #3 clamp to the T-bracket, with a bow in the cable to flex when the differential is moving. From the T-bracket to the control lever it should be in a straight line. The control lever or the T-bracket may need to be bent to accomplish the straight line.

ILLUSTRATION 7

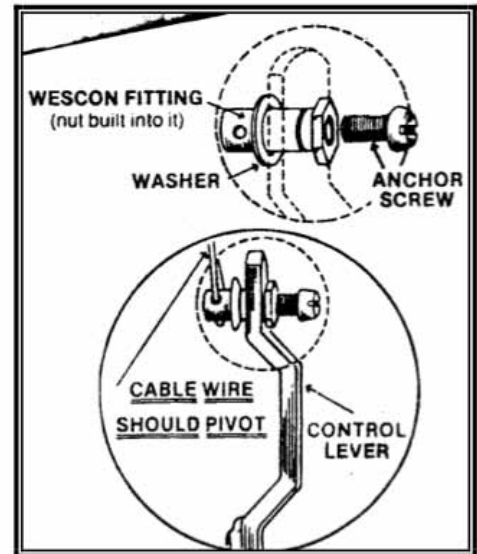

Part XIII: Testing

- a. Now check that the shift cable operates smoothly. Lower the car and sit in the driver's seat with the engine off, parking brake set and the transmission in neutral.
- b. Pull the control knob to disengage the drive shaft. Two fingers pulling forward on the knob should pull with ease. Pushing the cable back in should be the same. You should be able to click it in and out of gear with ease.

NOTE: If the cable knob does not pull out or push in easily recheck the shifter linkage adjustments and the routing of the shift cable.

Part XIV: Disengaging and engaging the drive shaft

- a. Getting ready to tow the vehicle, start by attaching the vehicle to the motor home with the tow bar. Once attached, go to the driver's seat and start the vehicle's engine. Place the transmission in Neutral and turn the ignition key off as far as it will go. The dash lights should now be turned off. Pull the shift knob out to disengage the drive shaft for towing. Once it is disengaged, shift the transmission lever into Park. If the vehicle is 4WD see NOTE paragraph c below. The vehicle is now ready to be towed.
- b. Do not touch the ignition key. It is now in the correct position for towing. The vehicle will

track and follow behind the motor home. With the key in this position it will not run the battery down on most vehicles. On some vehicles a fuse may have to be pulled to shut any dash lights off, and to keep from running the battery down.

- c. **NOTE: 2WD--Tow the automatic transmission vehicles in Park. Manual transmission vehicles are to be towed in Neutral. NO EXCEPTIONS!!**

4WD—Tow in 2WD when with automatic transmission. Tow in Neutral when with manual transmission.

- d. This step will teach you how to engage the drive shaft on an **automatic transmission** when it is disengaged. With the control knob pulled out, start the engine with the transmission in Neutral. Now shift the transmission into Drive. Since the drive shaft is disengaged, you can look at the speedometer needle on the dash, which should be running at 15-20 mph but you are sitting still. This speed is way too fast to engage the drive shaft and it would make a lot of noise if you tried. Leave the transmission in Drive and shut the ignition key off. Watch the speedometer needle slow down. Before it stops, about 4 or 5 mph, push the control knob in. When you shut the key off, be ready because the drive shaft comes to a stop quickly. The splines on the drive shaft coupling will line up and the collar will slide across the splines and lock in for driving.
- e. For **manual transmission** vehicles start the vehicle up and place the transmission in first gear. Let out on the clutch and watch the speedometer needle running about 15- 20 mph. With the vehicle still running, push in on the clutch and watch the needle slow down. As the needle slows down to about 5mph. push in on the control knob. The splines will line up and lock into gear for driving.
- f. You can practice engaging the drive shaft by doing the above steps. The more practice you have doing it, the easier it will be engaging the drive shaft when it is time to use it on the trip or vacation.
- g. Each vehicle is a little different. You can practice engaging the drive shaft at a faster speed or a slower speed. Your vehicle may require pushing in on the control knob at 6 or 7 mph. Maybe you need to push on the control knob as soon as you turn the ignition key off. Every vehicle is a little different. Practice, practice, practice. Practice makes perfect.
- h. Starting the vehicle up in neutral and placing the lever into drive will turn the transmission and the drive shaft. Never try to place the transmission lever into Park until the transmission has come to a complete stop. Let it stop or it will damage the transmission. Always start the vehicle in Neutral and then go to Drive when engaging the drive shaft. (If you start the vehicle in Park you would move the selector lever through Reverse, which would turn the drive shaft in the wrong direction. Then, when you placed the selector lever in Drive the transmission would turn the drive shaft quickly the other direction possibly damaging the transmission.) Now you say, “what if I go from Park to Reverse and try to engage the drive shaft”? It will not work because the drive shaft is spinning the wrong direction for the splines on the coupling to engage.

NOTE: We never recommend that anyone get out of the vehicle and physically push the vehicle back and forth to engage the drive shaft.

Part XV: Maintenance

- a. A mechanical product needs maintenance. The problem with the drive shaft is that it is out of sight out of mind. You might not use it except on your summer vacation, but when you do, you want it to work right there and now. A little maintenance goes a long ways.
- b. When you are doing your scheduled oil change, look at the drive shaft disconnect. Do a visual inspection on the shifter assembly. If it has chunks of dirt, sand and gravel, or ice and snow, clean it. Then take a product like WD-40 and spray liberally the linkage on the shifter assembly and on the splined drive shaft parts. The collar that slides across the splines has two spring loaded ball bearings. Spray liberally under the collar to wash any debris under it and to keep the springs and ball bearings operating smoothly.
- c. Take rags or paper towels and wipe the splines and the shifter assembly clean and dry. The WD-40 will accumulate dust and dirt. Wipe the unit dry to prevent this accumulation. Check the linkage assembly for any loose bolts or physical damage from road hazards. Look closely at the shift blocks in the collar to make sure they are not wearing uneven. The shifter assembly may need to be adjusted or fine-tuned. Refer to **Part XI-Adjusting the shifter linkage assembly**. This part of the instructions will keep the unit adjusted so the shift blocks and other parts do not wear out prematurely.
- d. Do not use oil or grease on the coupling. This attracts dirt and causes the unit to become inoperable.
- e. The drive shaft coupling and shifter linkage are zinc chromate plated. If it is kept clean and adjusted it will work properly and last many years. Remember a little maintenance goes a long ways.

TYPICAL PARTS ILLUSTRATION

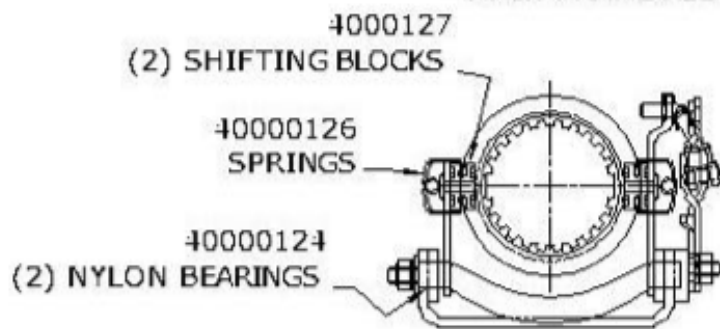
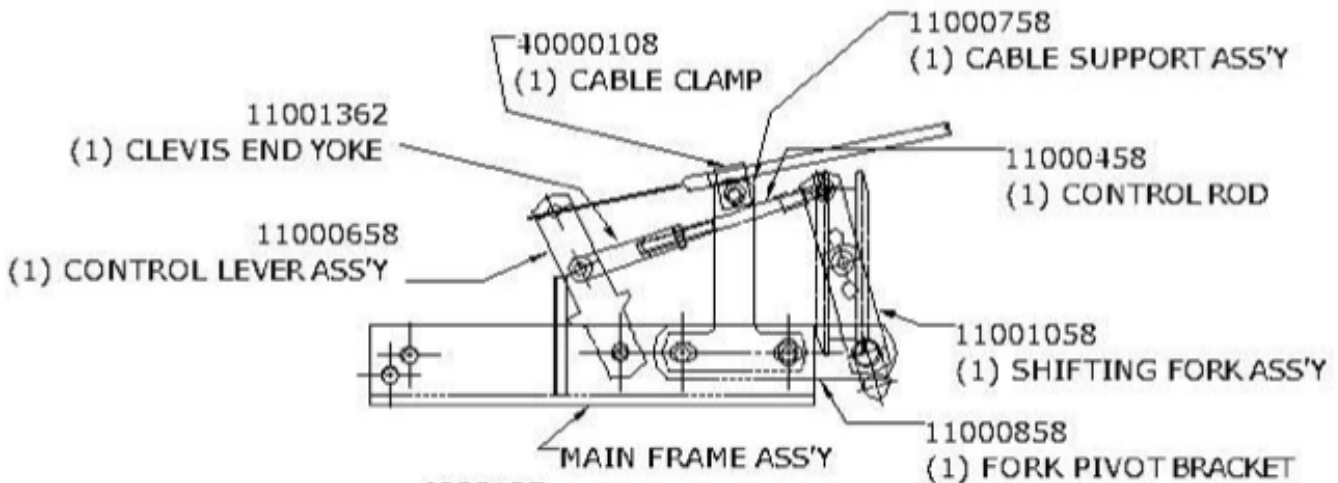
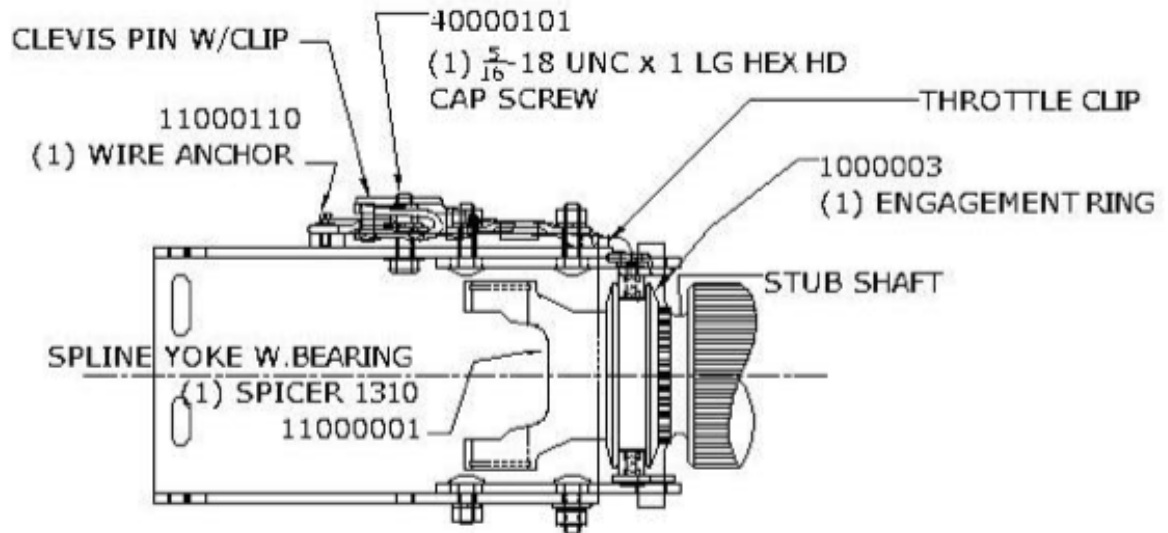

PARTS IN SPLINE YOKE ASS'Y
NOT SHOWN

- 1- $\frac{3}{8}$ -16 x 1 $\frac{1}{2}$ LNG. SOCKET
- 1- $\frac{3}{8}$ BELLEVILLE SPRING (40000000)
- 1- RETAINING RING (40000001)
- 1- BEARING (40000002)
- 1- $\frac{1}{4}$ S.S. BALL (40000003)
- 1- SPRING (40000005)

Part XVIII: Drive Shaft Re-work

1. Cut off the rear end of the drive shaft 4-3/16 inches (plus an allowance for the weld gap) from the yoke bearing center.
2. Disassemble drive shaft coupling assembly by removing hex socket head cap screw.
Warning: Do not lose the 1/4" steel balls and springs when sliding the shift collar off the stub shaft. Balls and springs are located 90 deg. to the wide tooth in the stub shaft.
3. Stub shafts are available for 2-1/2, 2-3/4, 3, 3-1/2 and 4" drive shaft diameters with .065" wall thickness. Stub shafts must be machined to fit smaller and/or thicker walled tubes. To calculate press fit diameter use the tube O.D. less 2 times the wall thickness plus .005-.007".

CAUTION: Turned diameter must be concentric with the original diameter within .001 t.i.r. (total indicator reading).

4. Press the stub shaft into the tube. Caution: Cross holes for the springs and balls must be located 90 deg. to the drive shaft yoke center line on the far end of the shaft. This will result in proper timing of the yokes.
5. Rotate the shaft assembly on the lathe centers and inspect with a dial indicator. Maintain concentricity at pressed joint.
6. Weld, straighten and check concentricity. Balance if necessary.
7. Reassemble the shift collar with springs and balls onto the splines of the stub shaft, making certain that the chamfered ends of the spline teeth face away from the shaft. Install the splined yoke with the hex socket head cap screw. Torque the cap screw to 38-40 ft./lbs.



Phone Number:

1-855-44REMCO (855-447-3626)

Fax Number:

1-855-839-2924

Address:

**RemcoDSC
4060 Dixon Street
Des Moines IA 50313**

Email:

sales@remcodsc.com